



## **WLAN Express Setup and Best Practices Deployment Guide**

[WLAN Express Setup and Best Practices Deployment Guide](#) **2**

[Introduction](#) **2**

[Supported Controllers and APs](#) **4**

[Installing WLC](#) **5**

[RF Profiles Configurations](#) **16**

[Monitoring Dashboards](#) **17**

[Best Practices Configurations](#) **20**

Revised: April 29, 2015,

# WLAN Express Setup and Best Practices Deployment Guide



## Introduction

In release 8.1 of Unified WLC software, Cisco introduces a new simplified first time out of box installation and configuration interface for 2500, 5500, 7500, and 8500 wireless series controllers. The goal of this deployment guide is to provide a set of instructions to help easily setup a WLC to operate in a small, medium, or large network wireless environment, where access point(s) can join and together as a simple solution and provide various services, such as corporate employee or guest wireless access on the network.

With this **WLAN Express** setup software release, there is a new GUI simplified controller express setup in addition to two legacy ways to configure the Unified Wireless LAN Controller:

- Traditional command line interface (CLI) via serial console
- Updated method using network connection directly to the WLC GUI setup wizard

This guide provides instruction only for using the WLAN Express GUI setup wizard. Note that the WLAN Express Setup can be used only for the first time in out of box installations or when controller configuration is reset to factory defaults.

## Configuring WLC

The general steps to configure the WLC are as follows:

## Procedure

---

- Step 1** Complete the configuration checklist.
  - Step 2** Unpack, connect, and power on the WLC.
  - Step 3** Connect a client machine to Service Port of the WLC with an Ethernet cable.
  - Step 4** Open a client web browser to access the WLC startup GUI.
  - Step 5** Enter the settings from the completed configuration checklist.
  - Step 6** Disconnect the WLC from client machine and connect to the network switch.
  - Step 7** Connect access point(s) to the network switch.  
Access points join the WLC, and the configured wireless network become available.
  - Step 8** Connect wireless client(s) to the available network.
- 

## Configuration Checklist

The following checklist helps you to make the installation process easier, while using the GUI wizard to configure the WLC. While most of the information from the list is mandatory, there is some information that is optional (\*). Take a moment to fill out:

- Network switch requirement (see above reference for switch configuration example):
  - WLC switch port number assigned
  - WLC assigned switch port
  - Is the switch port configured as trunk?
  - Is there a management VLAN? Management VLAN ID
  - Is there a guest VLAN? Guest VLAN ID
  
- WLC Settings:
  - New admin account name
  - Admin account password
  - System name for the WLC
  - The current time zone
  - Is there a NTP server available? NTP server IP address
  - WLC Management Interface:
    - IP address
    - Subnet mask
    - Default gateway
  - Management VLAN ID

- Corporate Wireless Network
- Corporate wireless name/SSID
- Is a RADIUS server required?
- Security authentication option to select:
  - WPA/WPA2 Personal
  - Corporate pass phrase (PSK)
  - WPA/WPA2 Enterprise)
  - RADIUS server IP address and shared secret
  - Is a DHCP server known? DHCP server IP address
- Guest Wireless Network - optional:
  - Guest wireless name/SSID
  - Is a password required for guest?
  - Guest pass phrase (PSK)
  - Guest VLAN id (use id)
  - Guest networking:
    - IP address
    - Subnet mask
    - Default gateway
- Advanced option—Configure RF Parameters for Client Density as Low, Medium, or High.

## Supported Controllers and APs

The following controllers and APs are supported:

- Cisco 2500, 5500, 7500, 8500 series wireless LAN controller.
- Cisco WLC 8.1 supported APs; see 8.1 Release Notes for the list of supported APs.

# Installing WLC

## Procedure

**Step 1** Connect a PC laptop's wired Ethernet port directly to Service Port of the WLC ( see the following figure for Service Port location). The port LEDs blink to indicate that both machines are properly connected.

**Figure 1: Service Port Location**



**Figure 2: Sample of Initial Wireless Network Configuration; IP Addresses Used as an Example**

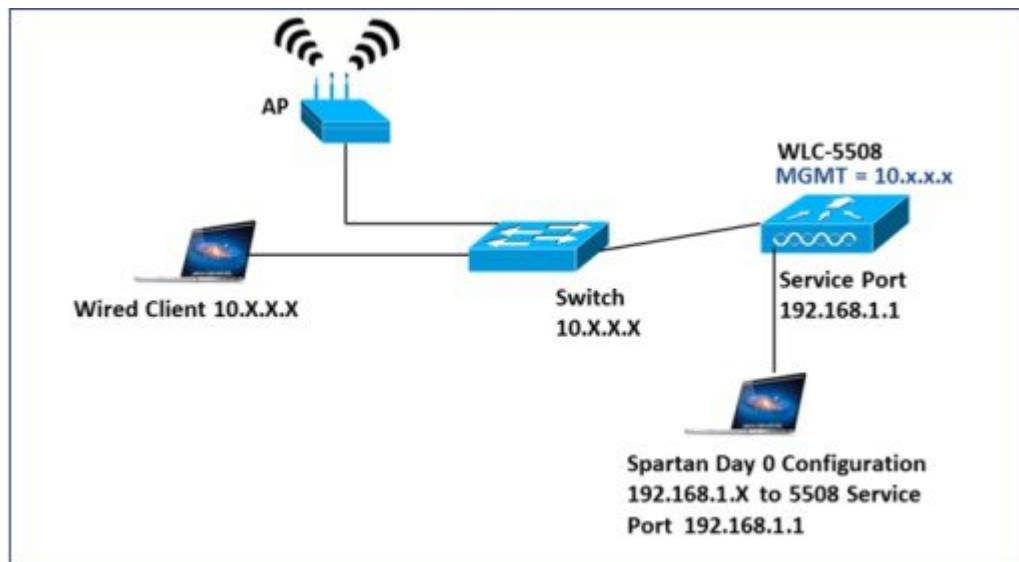

**Note** It may take several minutes for the WLC to fully power on to make the GUI available to the PC. Do not auto configure controller.

```
AUTO-INSTALL: TFTP status - '% Error: Config file transfer failed - No reply from the TFTP server'
AUTO-INSTALL: process terminated -- no configuration loaded
```

The LEDs on the front panel provide system status:

- The system is not ready – LEDs is OFF
- The controller is ready – LED is solid green



**Step 2** Configure DHCP option on the Laptop that you are connecting to the Service port. This assigns an IP address to your Laptop from the Controller service port 192.168.1.X or you can assign a static IP address 192.168.1.X to your Laptop to access the WLC GUI; both options are supported. The following figure shows an example of the Mac Laptop getting an IP address from the DHCP service port for the initial configuration of the controller.

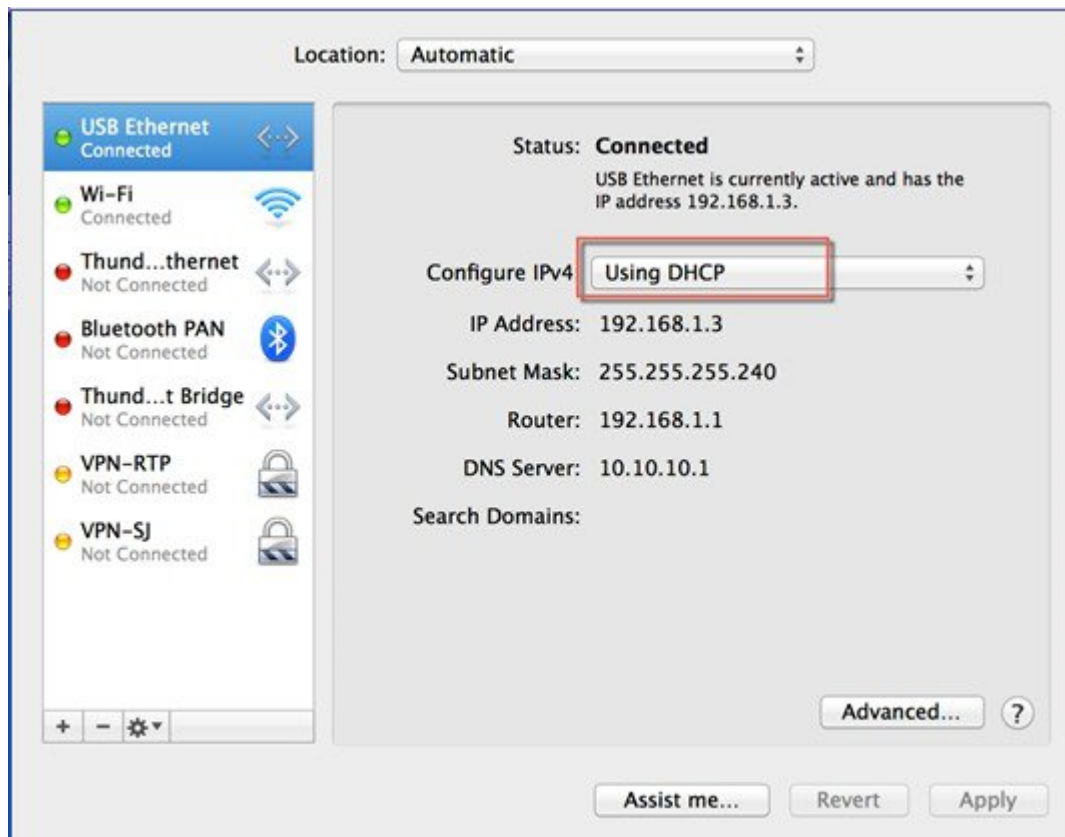

The following figure shows an example of network settings on Windows PC (**Start > Run > CMD > ipconfig**).

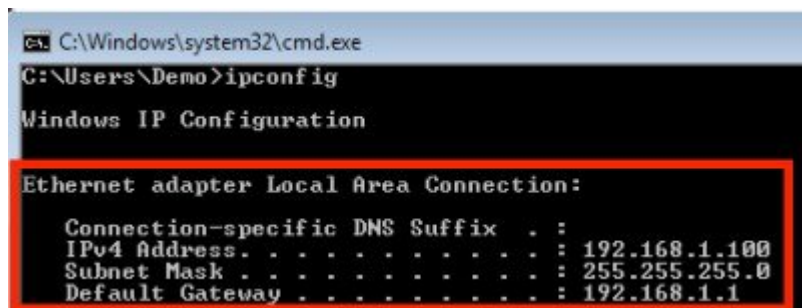

**Step 3** Upon confirming that there is an IP address of **192.168.1.x** assigned to your computer, open a web browser (preferably Chrome and Safari) and open the URL: **http://192.168.1.1**. The following screen appears in your browser.

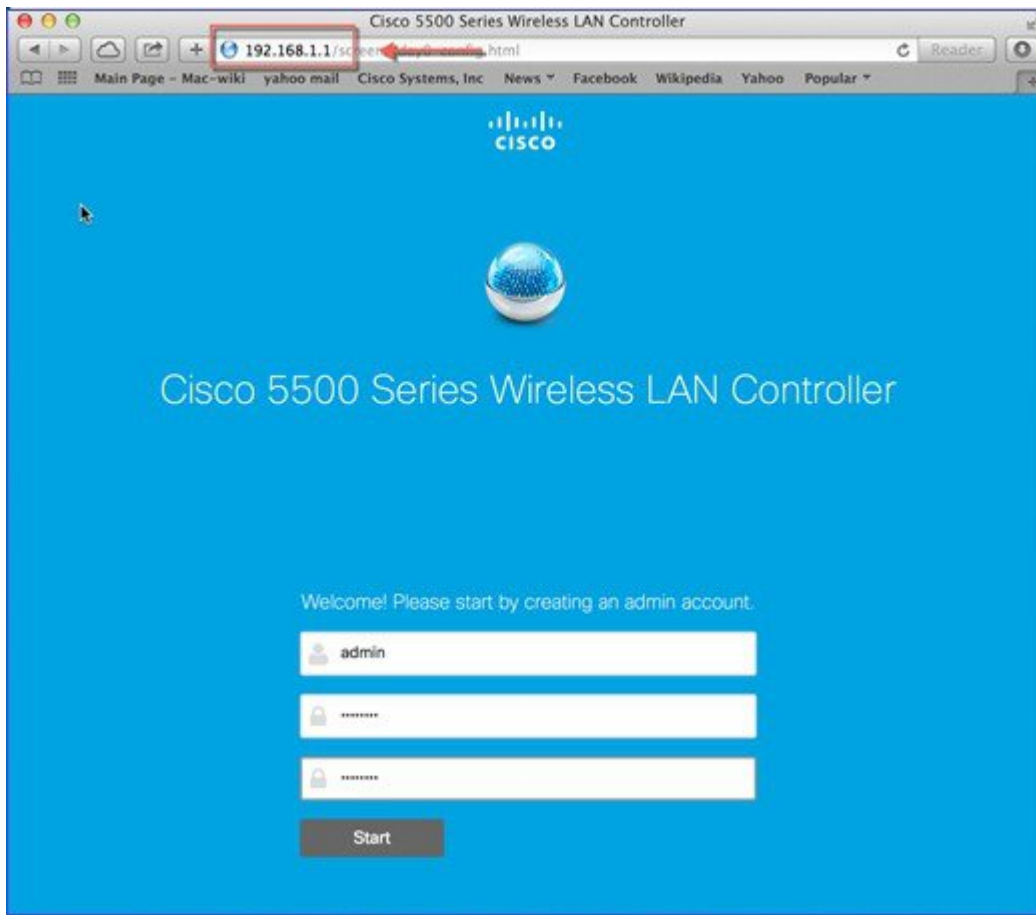

**Note** Keep the checklist that you have prepared earlier, as this will be very helpful to proceed with the following steps.

To create an admin account, do the following:

- 1 Create a new admin account name, for example, **admin**.
- 2 Provide the new admin account's password, for example, **Cisco123**.
- 3 Confirm the password.
- 4 Click **Start** to continue.

**Step 4** Once you are logged into the controller, in the **Set Up Your Controller** screen, with the help of the checklist, fill in the following:

- System name for the WLC, for example, **5508-BP**
- The current time zone
- NTP Server (optional)
- Management IP address, subnet mask, and default gateway, such as **10.70.0.75**, **255.255.255.0**, and **10.70.0.1**, respectively



- Management VLAN ID (see checklist), if left unchanged (or 0), then the network switch port must be configured with a native VLAN **X0**

**Note** The wizard will attempt to import the clock information (date and time) from the computer via JavaScript. It is highly recommended that you confirm this before continuing. Access points rely on correct clock settings to be able to join the WLC.

**Figure 3: Sample configuration for 5508**

The screenshot shows the configuration wizard for a Cisco 5500 Series Wireless LAN Controller. The title bar reads "Cisco 5500 Series Wireless LAN Controller". The current step is "1 Set Up Your Controller". The form includes the following fields:

- System Name: 5508-BP
- Country: United States (US)
- Date & Time: 01/22/2015, 14:36:16
- Timezone: Eastern Time (US and Canada)
- NTP Server: 0.0.0.0 (optional)
- Management IP Address: 10.70.0.75
- Subnet Mask: 255.255.255.0
- Default Gateway: 10.70.0.1
- Management VLAN ID: 0

At the bottom right, there are "Back" and "Next" buttons.

**Step 5** In the **Create Your Wireless Networks** screen, in the **Employee Network** area, with the help of the checklist, fill in the following:

- Network name/SSID, for example, **cisco-bp**
- Security, for example, **WPA/WPA2 Personal**

- WPA/WPA2 Personal—Provide a pass phrase (PSK /for example, **Cisco123** and confirm the pass phrase)
- Provide the DHCP server address (for example, **10.70.0.1**). If left empty, the DHCP processing is bridged to the management interface.

**Figure 4: Example of an Employee Network Configured with WPA/WPA2 Personal Using PSK (pre-shared key / pass phrase) for 5508-bp**

The screenshot shows a configuration interface for wireless networks. At the top, there are two steps: '1 Set Up Your Controller' and '2 Create Your Wireless Networks'. The 'Employee Network' section is active, indicated by a green toggle switch. Below this, there are several input fields: 'Network Name' with the value 'cisco-bp', 'Security' set to 'WPA2 Personal', 'Pass Phrase' and 'Confirm Pass Phrase' both masked with dots, 'VLAN' set to 'Management VLAN', and 'DHCP Server Address' set to '10.70.0.1'. A 'Guest Network' section below is inactive, with a grey toggle switch. At the bottom, there are 'Back' and 'Next' buttons.

**Step 6** (Optional) In the **Create Your Wireless Networks** screen, in the **Guest Network** area, with the help of the checklist, fill in the following:

- Network name/SSID, for example, **bp-guest**
- Security, for example, **Web Consent**

- VLAN IP address (for example, **10.76.0.2**), VLAN ID (for example, **76**), and DHCP server IP address (for example, **10.76.0.1**)

**Figure 5: Example of a Guest Network Configured with Web Consent for 5508-bp**

Guest Network

Network Name

Security

VLAN

VLAN IP Address

VLAN Subnet Mask

VLAN Default Gateway

VLAN ID

DHCP Server Address

3 Advanced Setting

**Step 7** In the **Advanced Setting** screen, in the **RF Parameter Optimization** area, do the following:

- 1 Select the client density as Low, Typical, or High.
- 2 Configure the RF parameters for RF Traffic Type, such as Data and Voice.
- 3 Change the service port IP address and subnet mask, if necessary.

1 Set Up Your Controller

2 Create your Wireless Networks

3 Advanced Setting

RF Parameter Optimization

Client Density  Low Typical High

Traffic Type

Virtual IP Address

Local Mobility Group

Service Port Interface

Service Port IP Address

Service Port Netmask

Back Next

**Step 8**

Click Next.

The following table depicts the default values when Low, Typical, or High deployment type is selected from RF parameters.

	dependency	Typical (Enterprise - default profile)	High Density (Throughput)	Low Density (Coverage Open Space)	Legacy (if disabled RF opt)
Tx Power  (Following three items are equivalent to Tx Power) TPC threshold TPC min TPC max	Global per band  Specific RF Profile per band	default  TPC Min default (-10) TPC Max default (30)	<b>Higher</b>  TPC threshold -65db 5G -70 for 2.4 TPC min +7dbm TPC max default (30)	Highest (1)  threshold: 5G -60db 24G -65db  TPC Min - Default(-10) TPC max - default (30)	default
Rx Sensitivity (rxsop)	Global per band (Advanced Rx Sop) RF profiles	default (auto)	medium (rxsop)	low	default
CCA Threshold	Global per band 802.11 a only (hidden) RF Profile	default (0)	default (0)	default(0)	default
Coverage RSSI Threshold	Global per band data and voice RSSI in (Coverage) RF Profile	default (Data : -80 Voice : -80)	default (Data : -80 Voice : -80)	Higher (Data : -90 Voice : -90)	default
Coverage Client Count	Global Per band (Coverage Exception) RF Profiles (Coverage Hole Detection)	default (3)	default (3)	Lower (2) (1-3)	default
Data Rates	Global per band (network) RF Profiles	12 Mbp mandatory 9 supported 1,2, 5.5, 6, 11 Mbp disable	12 Mbp mandatory 9 supported 1,2, 5.5, 6, 11 Mbp disable	CCK rates enable 1,2, 5.5, 6, 9,11,12 Mbp enable	default

**Note** When the controller is configured, you can verify or change the same Best Practices RF Optimization setting via the Controller Advanced Interface as documented in the [RF Profiles Configurations](#), on page 16 section.

**Step 9** If all the settings are correct, click **Apply**. A message appears with a prompt 'System will reboot...Do you want to apply these configuration?'



Please confirm settings and apply

1 Controller Settings

Username **admin**  
System Name **5508-BP**  
Country **United States (US)**  
Date & Time **01/22/2015 15:04:52**  
Timezone **Eastern Time (US and Canada)**  
NTP Server **-**

Management IP Address **10.70.0.75**  
Management IP Subnet **255.255.255.0**  
Management IP Gateway **10.70.0.1**  
Management VLAN ID **0**

2 Wireless Network Settings

Employee Network

Network Name **cisco-bp**  
Security **WPA2 Personal**  
Pass Phrase: **\*\*\*\*\***  
Employee VLAN **Management VLAN**  
DHCP Server Address **10.70.0.1**

<input checked="" type="checkbox"/> <b>Guest Network</b>	
Network Name	cisco-guest
Security	Web Consent
VLAN IP Address	10.76.0.2
VLAN Subnet Mask	255.255.255.0
VLAN Default Gateway	10.76.0.1
VLAN ID	76
DHCP Server Address	10.76.0.1
<b>3</b> Advanced Settings	
<input checked="" type="checkbox"/> <b>RF Parameter Optimization</b>	
Client Density	Typical
Traffic Type	Data and Voice
Virtual IP Address	1.1.1.1
Local Mobility Group	miadler
Service Port IP Address	192.168.1.1
Service Port Netmask	255.255.255.0
<input type="button" value="Back"/> <input type="button" value="Apply"/>	

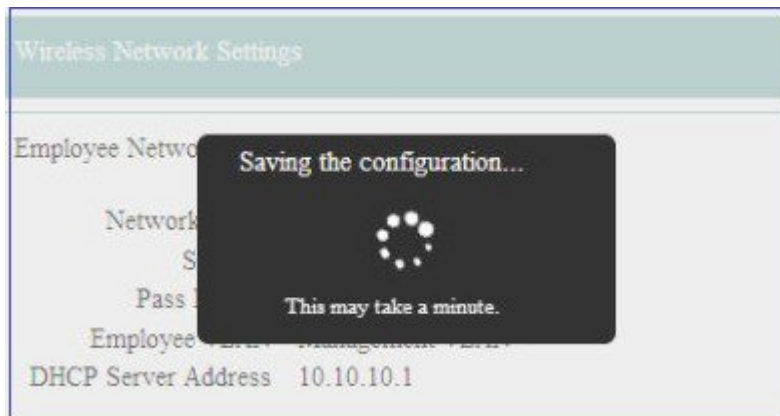

- Step 10** Click **OK** to apply final settings.  
 The WLC reboots automatically. A confirmation page will show that *'The controller has been fully configured and will now restart'*. If this message does not appear, do the following:
- 1 Disconnect your computer from the WLC service port and connect it to Switch port.
  - 2 Connect the WLC port 1 to the switch configured trunk port.
  - 3 Connect access points to the switch if not already connected.

- 4 Wait until the access points join the WLC.

## RF Profiles Configurations

After successful login as admin, you can verify whether the Configuration Express features are enabled by checking that the predefined RF profiles getting created under **WIRELESS > RF Profiles**.



Under **WIRELESS > Advanced > System Profile / Network Profile**, verify the following fields:







---

**Note** It is recommended to use RF and Network profiles configuration even if the WLAN Express setup was not used initially or if the controller was upgraded from the software prior to release 8.1.

---

## Monitoring Dashboards

In release 8.1 of the Wireless LAN Controller, a new Dashboard interface is introduced when initiating a Web UI connectivity to the controller. Previously, when connecting to the controller Management Interface, the user was able to see a summary of the controller monitor interface. In the web browser, enter the IP address of the management interface as previously configured and enter the admin credentials that were created earlier, that is, Login Name: **admin** and password **Cisco123**.

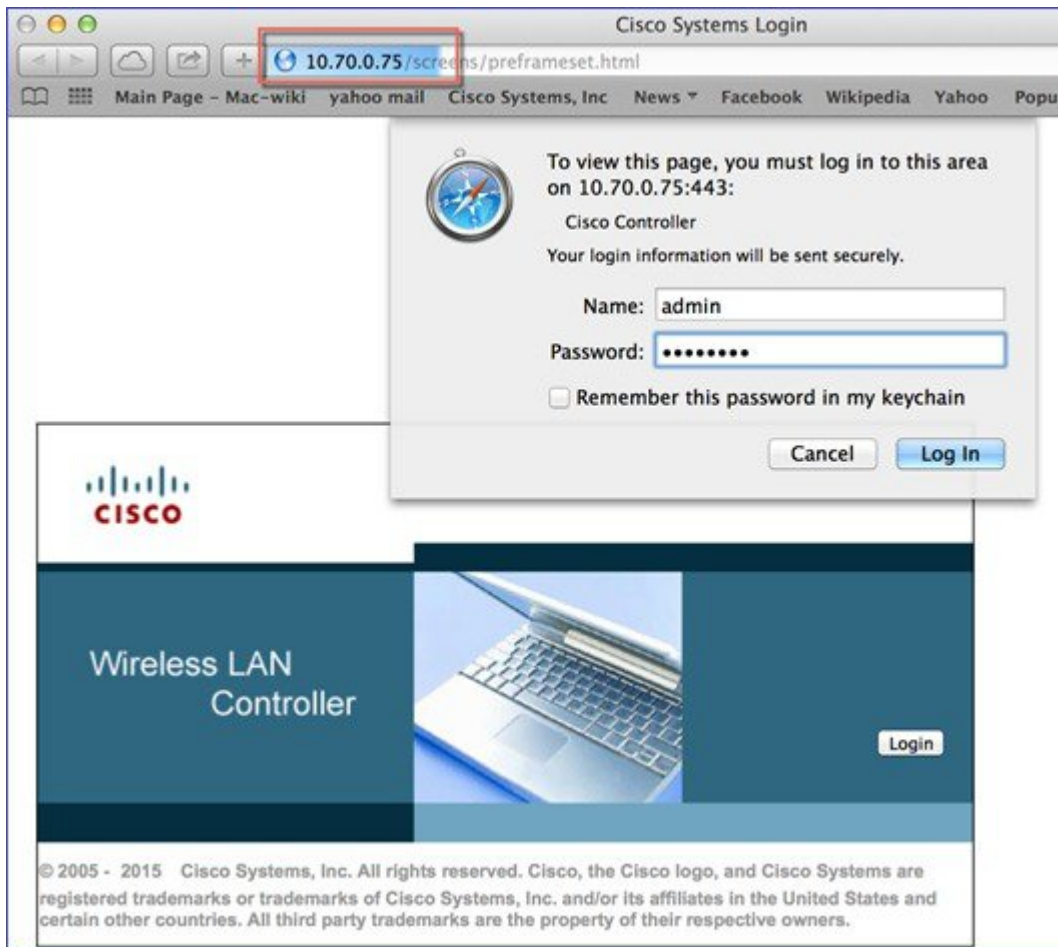

In release 8.1, a new interface is added to present the system administrator with additional practical at glance information. This new Monitoring interface contains several Dashboards and monitoring options. Upon connecting to the controller management interface, the **Network Summary** page is first displayed. The administrator can spend some time to explore this page, and then log into the WLC to access web UI and dashboard.

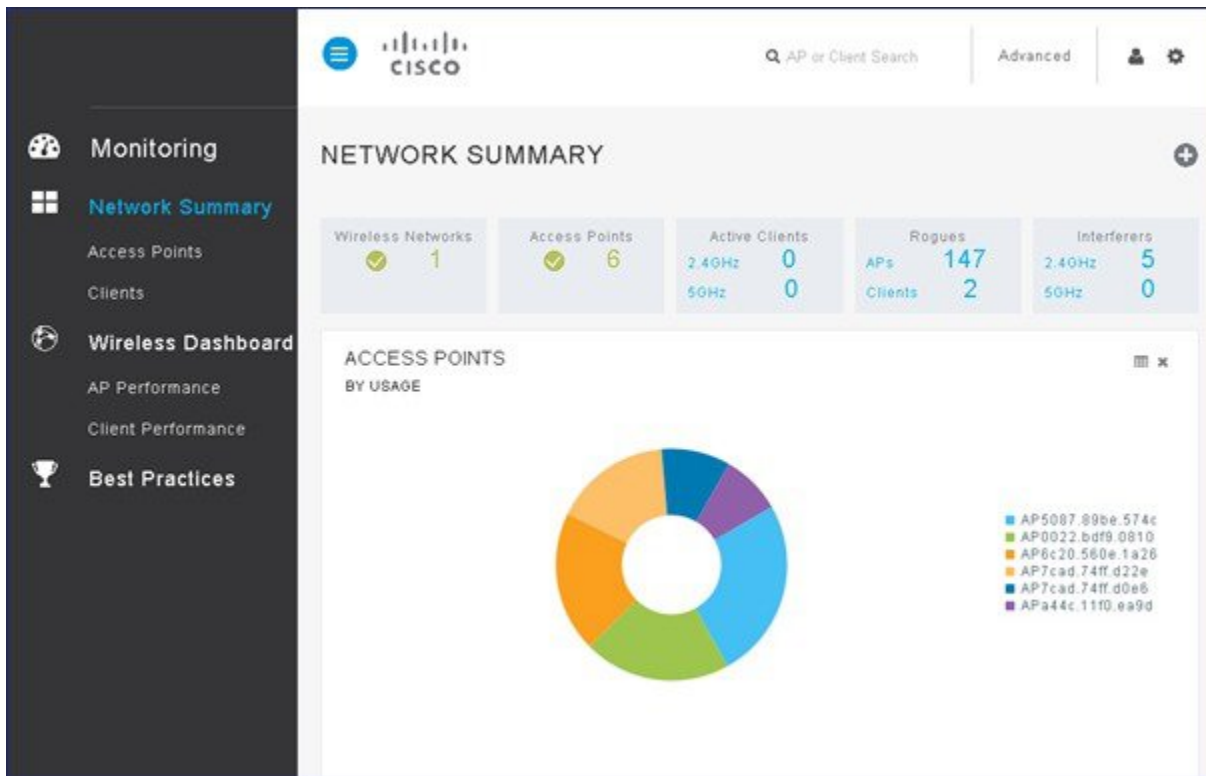

As shown in the left pane, the Monitoring interface allows you to choose **Network Summary**, **Wireless Dashboard**, or **Best Practices**. Network Summary has additional submenus to monitor the access points and clients.

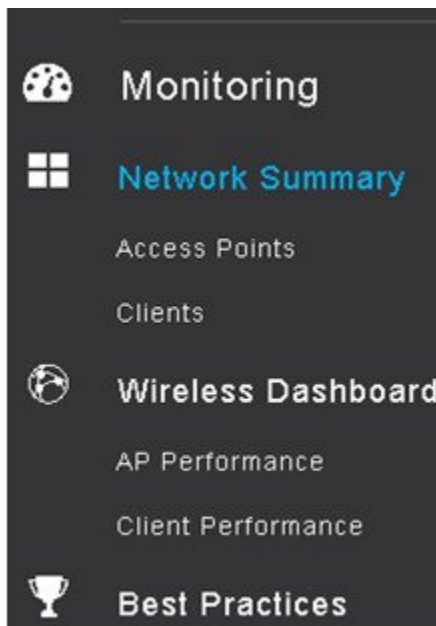

The following is a screenshot from the **Access Points** submenu, where the monitoring page displays information about 2.4 GHz and 5 GHz access points. The information gives the administrator a Bird's Eye view on the access point's valuable details.

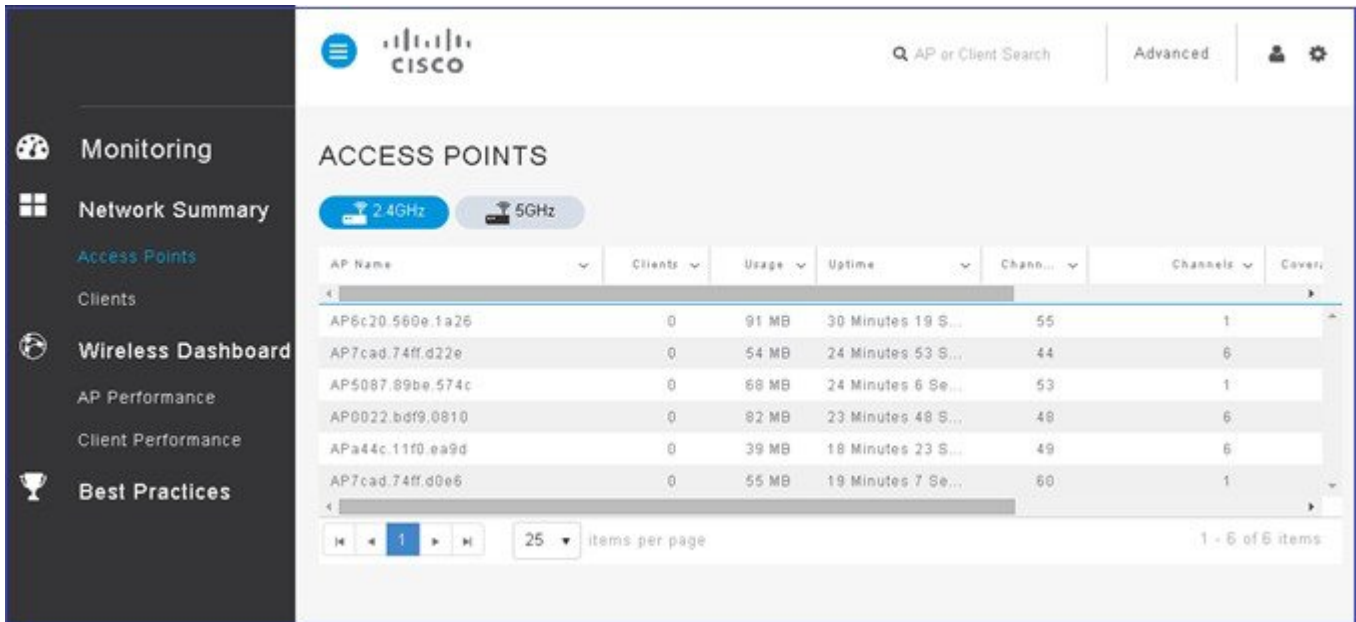

While choosing **AP Performance** under **Wireless Dashboard**, charts are displayed about various AP performance statistics, such as Channel Utilization - Top APs, Interference - Top APs, Client Load - Top APs, and Coverage Bottom APs.

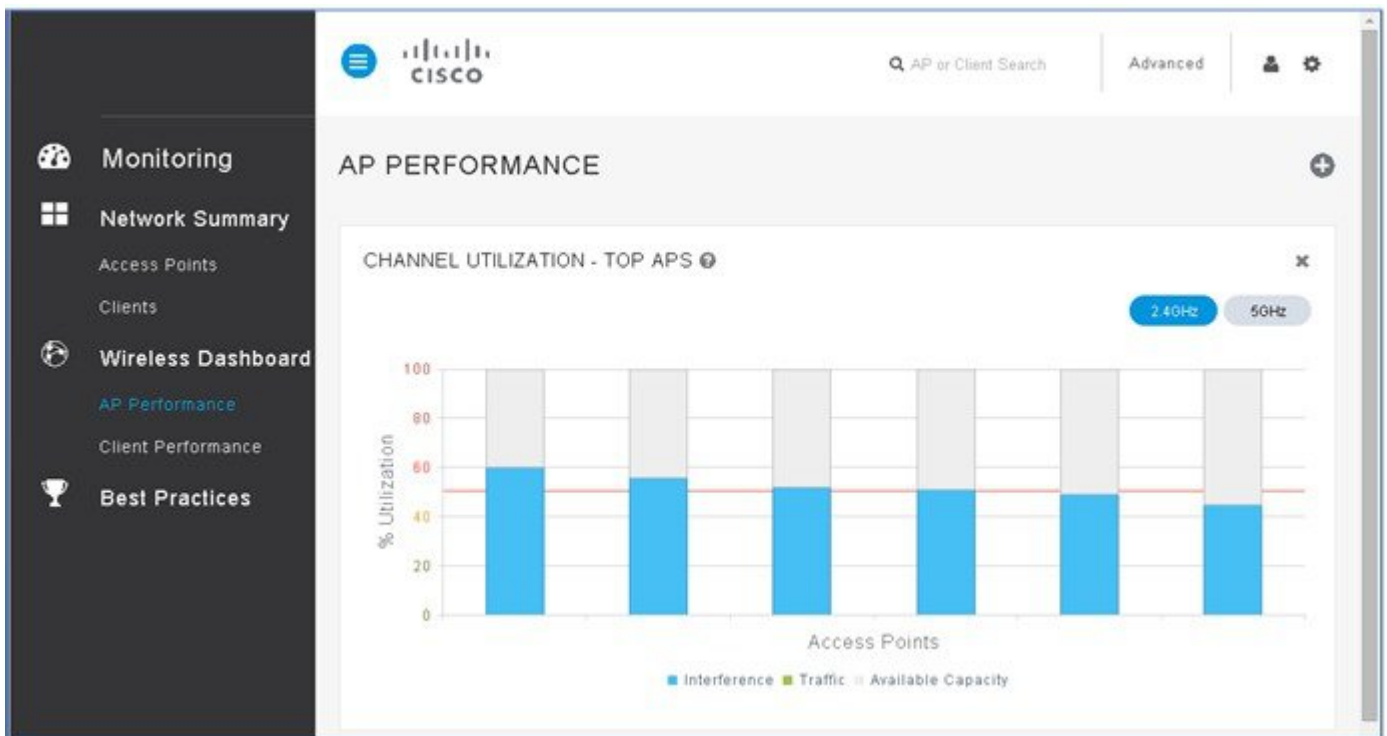

Few additional icons are available in the upper right corner of the dashboard as in the following figure.

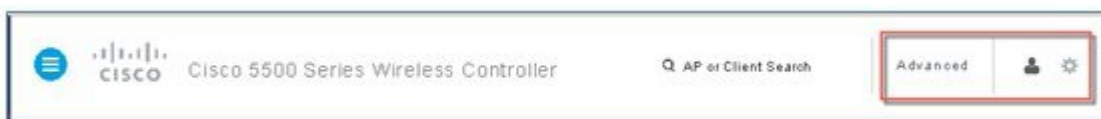

Click  icon to view the additional options.

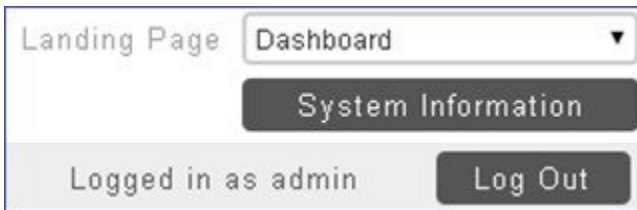

Click **Advanced** to view the legacy controller interface as shown in the following figure.



**Note** The  icon takes you back to the Dashboard Monitoring interface.

Click **Home** to view the information about:

- Network Summary
  - Access Points
  - Clients
- Wireless Dashboard
- AP Performance
- Client Performance
- Best Practices

## Best Practices Configurations

Click **Best Practices** to view the information about:

- Infrastructure

- Security
- RF Management

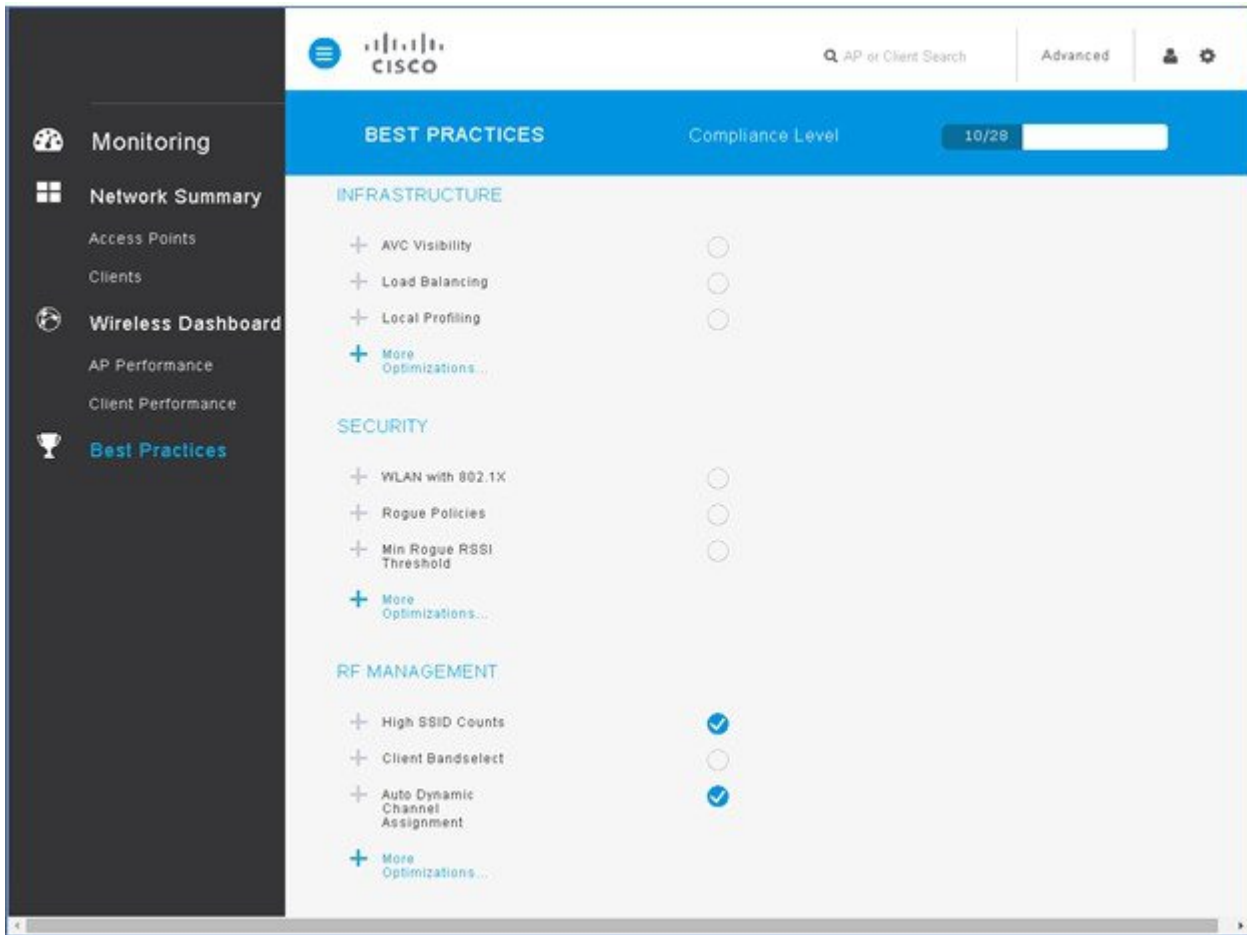

Few best practices parameters are configured by default as recommended by Cisco wireless experts. The level of compliance **10/28** represents this setting.

## BEST PRACTICES

Compliance Level



10/28

### INFRASTRUCTURE

- + AVC Visibility
- + Load Balancing
- + Local Profiling
- + Controller High Availability  ←
- + NTP
- + Fast SSID  ←
- + mDNS Gateway  ←
- + Management Over Wireless
- + HTTPs for Management
- + Aironet IE
- + Multicast Forwarding
- + Multicast Mobility



Less Optimizations...

**SECURITY**

- + WLAN with 802.1X
- + Rogue Policies
- + Min Rogue RSSI Threshold
- + SSH/Telnet Access
- + Client Exclusion  
- + Legacy IDS  
- + Local Management Password Policies
- + User login policies
- + CPU ACLs

[Less Optimizations...](#)

**RF MANAGEMENT**

- + High SSID Counts  
- + Client Bandselect
- + Auto Dynamic Channel Assignment  
- + Auto Transmit Power Control  
- + Auto Coverage Hole Detection  
- + CleanAir Detection
- + Event Driven RRM

[Less Optimizations...](#)

You can click the + icon to select a recommended best practice parameter, read an expert recommendation, and click **Fix it Now** or later reverse the BP configuration option by clicking **Restore Default**. Following is an example of BP Local Profiling configuration.

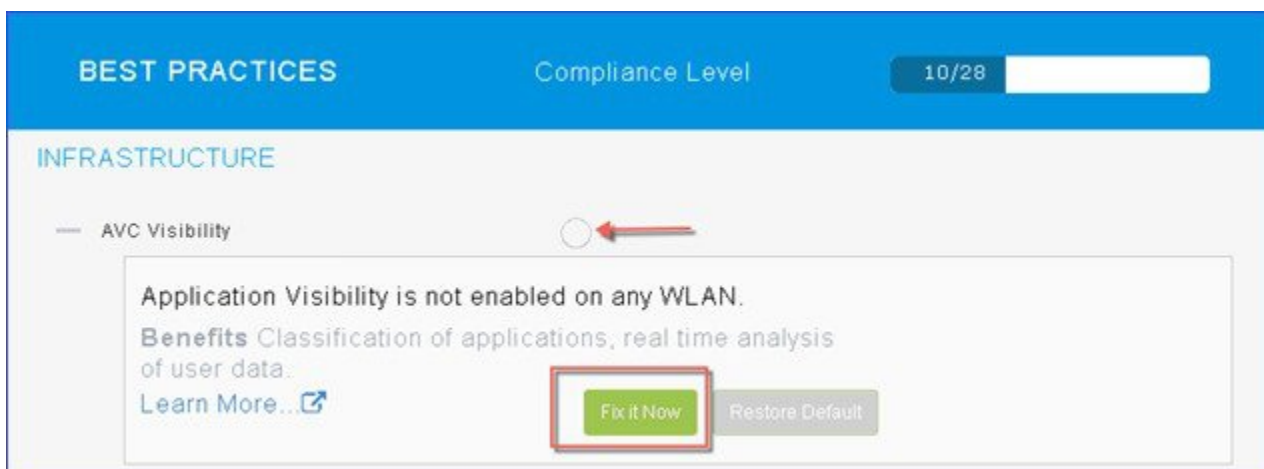

If you click **Learn More**, the Monitoring interface displays the Cisco Best Practices Configuration and Deployment Guide as in the following figure.

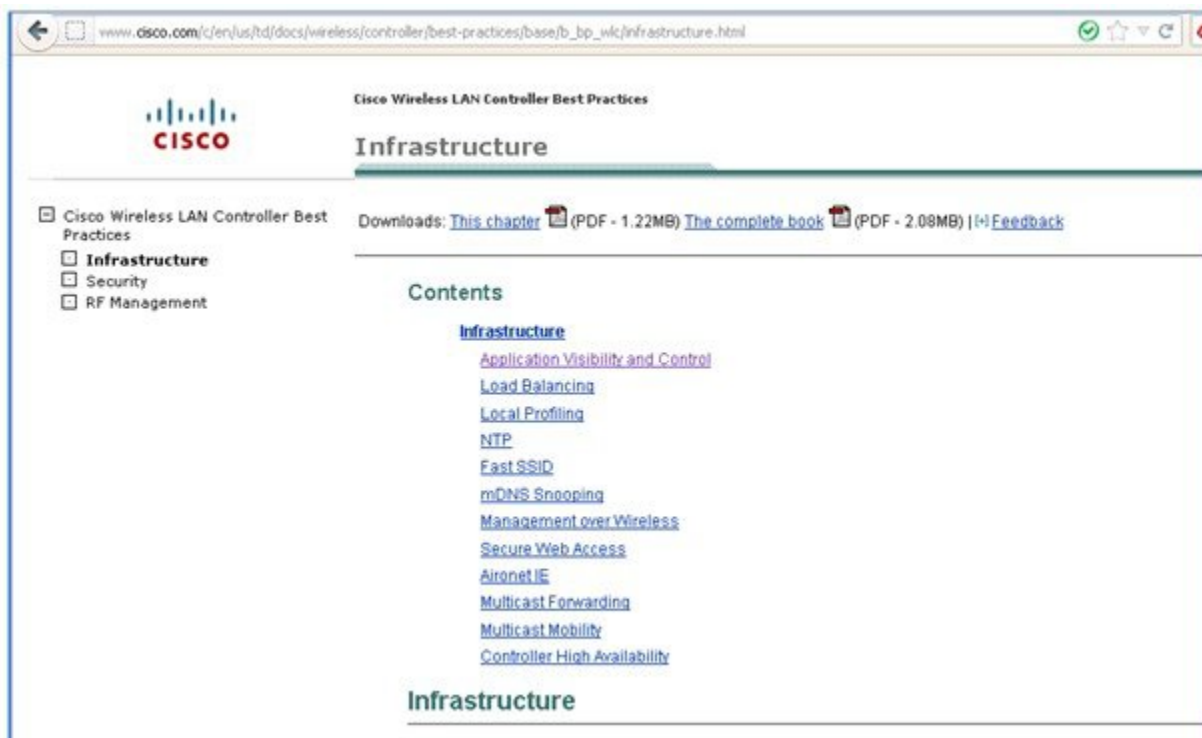

The following table shows all best practices recommendations in release 8.1.

Feature	8.1
AVC Visibility	Yes( 2504 only)
mDNS Snooping	Yes
New MDNS Profile for printer, http	Yes



<b>Feature</b>	<b>8.1</b>
Local Profiling	Yes
Band Select	Yes
DHCP Proxy	Yes
Secure Web access	Yes
Virtual IP 192.0.2.1	Yes (configurable)
RRM-DCA Auto	Yes
RRM-TPC Auto	Yes
CleanAir Enabled	Yes
EDRRM Enabled	Yes
Channel Width 40 MHz	Yes
Aironet IE Disabled	Yes
Management over Wireless	No
2.4 Low Data Rates Disabled	Yes (network profile)
Load Balancing	Yes (network profile)
Rogue Threshold Enabled	Yes
Client Exclusion Enabled	Yes
FastSSID Enabled*	Yes
Infra MFP	Yes
Multicast Forwarding Mode	Yes
SNMPv3 (delete default)	Yes
Mobility Name	Yes
RF Group same as Mobility Name	Yes
DHCP Required on Guest WLAN	Yes
5 GHz Channel Bonding*	Yes





**Americas Headquarters**  
Cisco Systems, Inc.  
San Jose, CA 95134-1706  
USA

**Asia Pacific Headquarters**  
Cisco Systems (USA) Pte. Ltd.  
Singapore

**Europe Headquarters**  
Cisco Systems International BV  
Amsterdam, The Netherlands

Cisco has more than 200 offices worldwide. Addresses, phone numbers, and fax numbers are listed on the Cisco Website at [www.cisco.com/go/offices](http://www.cisco.com/go/offices).